

# CURTAINS and CHUTES

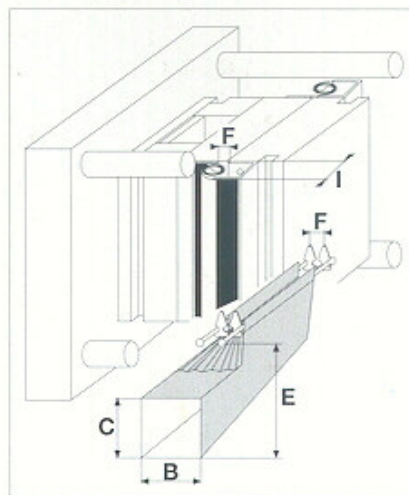

**MARTIPLAST**



Bent chute closed

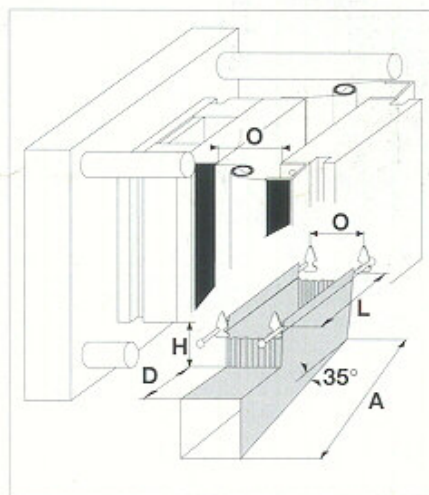

Bent chute opened

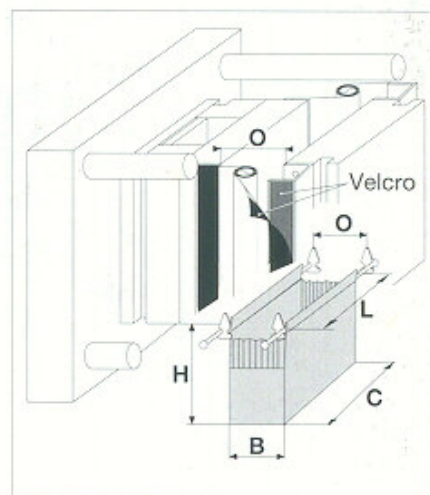

Straight chute

## MARTIPLAST CHUTES

MODELL-NR	L	H	O	A	B - C	D	E	F
25.25.20	250	250	350	630	200	320	660	30
30.20.20	300	200	350	630	200	320	660	30
30.25.25	300	250	350	630	200	320	710	30
30.30.25	320	300	350	630	200	320	760	30
30.35.30	300	350	350	630	200	320	810	30
35.30.30	350	300	500	750	250	320	800	30
35.35.40	350	350	500	680	250	320	850	30
45.40.40	460	400	500	800	250	320	900	30

## STRAIGHT CHUTES

Thank you to confirm the sizes L.H.O.B.C

## MARTIPLAST CURTAINS

References		
Height of the mold (mm)	Opening of the mold (mm)	
	500	760
150	150/500	-
200	200/500	200/760
250	250/500	250/760
300	300/500	300/760
350	350/500	350/760
400	400/500	400/760
450	450/500	450/760
500	500/500	500/760
550	550/500	550/760
600	600/500	600/760
650	650/500	650/760
Size F	5	5
Size I	35	35

## CHUTES :

Soft exhausting tunnel fixed under the mold, allowing to guide and to exhaust the injecting parts out of the mold, protecting them against any contamination providing from the injection moulding machine.

The soft design with a material resisting up to 80° and the fixing devices enable an easy adaptation and using.

## PROTECTING CURTAINS :

Enable to centralize the drop of the parts under the mold. They avoid any contamination or last of production, that can occur in the area of exhaust. The memory of the material used and the small size, make this product useful with all kind of mold (But at a maximum of 60°C).

Option : fixation by magnets.

Your contact :